

TECHNICAL MANUAL
OPERATOR'S, UNIT AND
DIRECT SUPPORT, MAINTENANCE MANUAL
(INCLUDING REPAIR PARTS AND SPECIAL TOOLS LIST)
FOR
KOEHLER KINEMATIC VISCOSITY BATH
MODEL K23380

This technical manual is an authentication of the manufacturer's commercial literature and does not conform with the format and the content requirements normally associated with Army technical manuals. This technical manual does, however, contain all essential information required to operate and maintain the equipment

Approved for public release; distribution is unlimited.

HEADQUARTERS, DEPARTMENT OF THE ARMY
28 SEPTEMBER 1990

This technical manual is an authentication of the manufacturer's commercial literature and does not conform with the format and the content requirements normally associated with. Army technical manuals. This technical manual does, however, contain all essential information required to operate and maintain the equipment.

Approved for public release; distribution is unlimited.

SUPPLEMENTARY INTRODUCTORY MATERIAL

1-1. Maintenance Forms and Records.

Department of the Army forms and procedures used for equipment maintenance will be those described by DA Pam 738-750, The Army Maintenance Management System.

1-2. Reporting Errors and Recommending Improvements.

You can help improve this manual. If you find any mistakes or if you know of a way to improve the procedures, please let us know. Mail your letters, DA Form 2028 (Recommended Changes to Publications and Blank Forms), or DA Form 2028-2 located in the back of this manual, directly to Commander, U.S. Army Troop Support Command, ATTN- AMSTR-MCTS, 4300 Goodfellow Blvd., St. Louis, MO 63120-1798. A reply will be furnished to you.

1-3. Destruction of Army Material to Prevent Enemy Use.

Refer to TM 750-244-3 for instructions covering the destruction of Army Material to prevent enemy use.

1-4. Administrative Storage of Equipment.

a. Placement of equipment in administrative storage should be for short periods of time when a shortage of maintenance effort exists. Items should be in mission readiness within 24 hours or within the time factors as determined by the directing authority. During the storage period appropriate maintenance records will be kept.

b. Before placing equipment in administrative storage, current preventive maintenance checks and services should be completed. Shortcomings and deficiencies should be corrected, and all modification work orders (MWO's) should be applied.

c. Storage site selection. Inside storage is preferred for items selected for administrative storage. If inside storage is not available, trucks, vans, Conex containers and other containers may be used.



K23300 & K23390

KINEMATIC VISCOSITY BATH

ASTM D445

KINEMATIC VISCOSITY OF TRANSPARENT

AND OPAQUE LIQUIDS

(AND THE CALCULATION OF DYNAMIC VISCOSITY)

SAFETY AND HAZARD WARNING

THIS EQUIPMENT MAY INVOLVE HAZARDOUS MATERIAL AND OPERATIONS. THIS MANUAL DOES NOT PURPORT TO ADDRESS ALL OF THE SAFETY PROBLEMS ASSOCIATED WITH THE USE OF THE EQUIPMENT. IT IS THE RESPONSIBILITY OF WHOEVER USES THIS EQUIPMENT TO CONSULT AND ESTABLISH APPROPRIATE SAFETY AND HEALTH PRACTICES, AND DETERMINE THE APPLICABILITY OF REGULATORY LIMITATIONS PRIOR TO USE.

KOEHLER

K23300 & K23390

KINEMATIC VISCOSITY BATH

TABLE OF CONTENTS

SECTION:

(A)

GENERAL INSTRUCTIONS:

- (1) UNPACKING INSTRUCTIONS
- (2) ASSEMBLY INSTRUCTIONS
- (3) OPERATING INSTRUCTIONS
- (4) SERVICE INSTRUCTIONS

(B)

WIRING DIAGRAM

(C)

SPARE PARTS LIST

NOTE:

Model K23390 Kinematic Viscosity Bath is the same as the K23300 except it is wired for 230 Volts, 50/60 Hz.

SECTION A

(1) UNPACKING INSTRUCTIONS: (see shipping diagram)

The K233 Bath comes packed in one carton. Remove the bath top (be careful of thermister probe taped to top) and place in safe location. The inner box is removed next, and the Pyrex Jar is unpacked. Inside the Jar are the tube holder parts packed separately. Remove the base and electronic control unit from the carton and carefully remove all packing and proceed to assemble the instrument.

(2) ASSEMBLY INSTRUCTIONS:

NOTE: The Kinematic Viscosity Bath should be assembled and placed on a firm level table in a room free of excessive drafts.

(A) Place the base ring on the firm level table and install the Pyrex Jar.

(B) Fill the Pyrex Jar with white technical oil to the level prescribed in ASTM D445. Distilled water may be used at 100°F or below.

CAUTION: Warranty will be voided if Ethylene Glycol is added to water as it is corrosive, abrasive, and will destroy plating on heaters & stirrer support bearings.

(C) Place the bath top on the Pyrex jar and plug the control cable (located at the rear of the bath top) into the receptacle on the top of the control box.

(D) Insert thermistor probe on cork provided and place in hole in top plate.

SECTION A

- (E) Plug the control box lead into a properly fused and grounded receptacle of the correct voltage as marked on the rear plate of the control unit.
- (F) Place the thermometer into the opening provided on the top of the bath.

(3) **OPERATING INSTRUCTIONS:**

- (A) Bath is now ready for operation. Make sure that all switches on the control box are OFF.
- (B) Turn line switch and continuous heater switch ON. Set right hand fine control to mid position. Move looking lever on coarse control all the way to the left; turn coarse control knob fully clockwise and pilot light will come on. Turn input switch to LOW for lower heat range and to HIGH for temperatures over 190°F. Bath will now heat rapidly.
- (C) When temperature of the bath is about 10° below the desired temperature turn the continuous heater control to OFF and turn coarse control knob counter-clockwise until pilot light goes OFF. Allow bath to stabilize then adjust temperature coarse control knob to make minor temperature adjustments.
- (D) When the desired temperature is reached and has stabilized, the bath is ready for testing.
- (E) Proceed to test in accordance with A.S.T.M. D445.

SECTION A

(4) **SERVICE INSTRUCTIONS:**

Under normal conditions service is not required. However, any service problem can often be resolved quickly and inexpensively by phone or letter.

Please contact our office at:

KOEHLER INSTRUMENT COMPANY, INC.
1595 SYCAMORE AVENUE
BOHEMIA, NEW YORK 11716

TELEPHONE: (516) 589-3800

TELEX: 4973677 KOEHLER

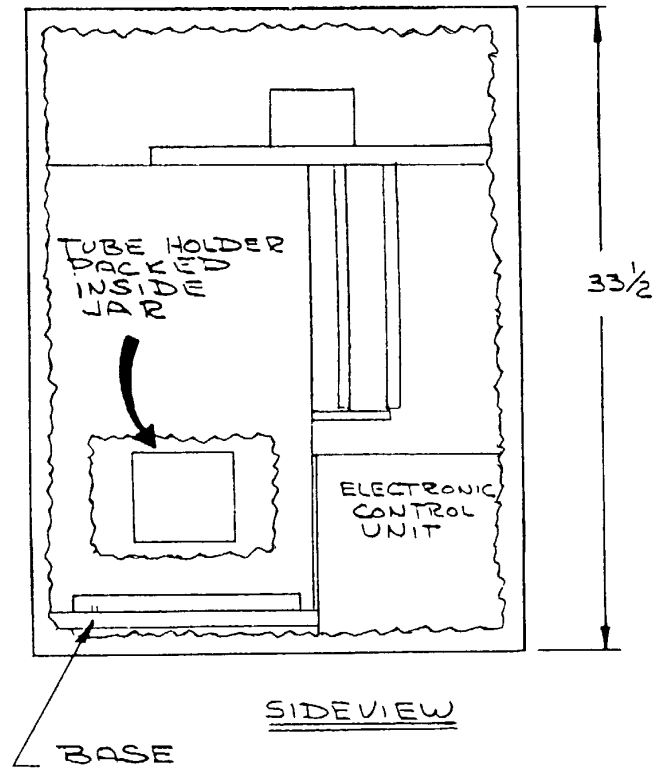
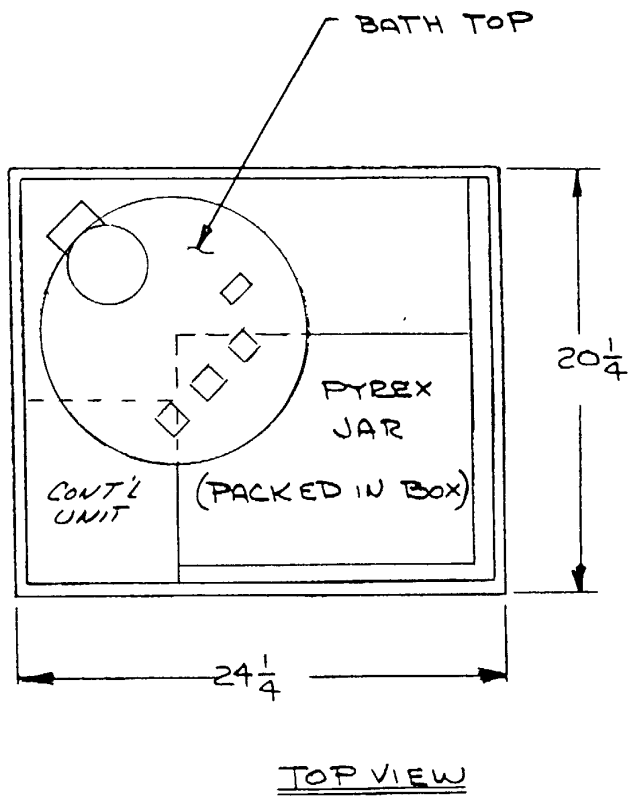

INSTRUMENT	K23300
MAT	<i>CORRUGATED</i> CARTON
FINISH	

NO REQD	
DWG SIZE	<i>A</i>

TITLE	
SHIPPING ARRANGEMENT	
SCALE	NONE
SHEET	1 OF 1

KOEHLER INSTRUMENT CO. INC 1595 SYCAMORE AVENUE BOHEMIA, N Y	
PART NO	REV
K23300	

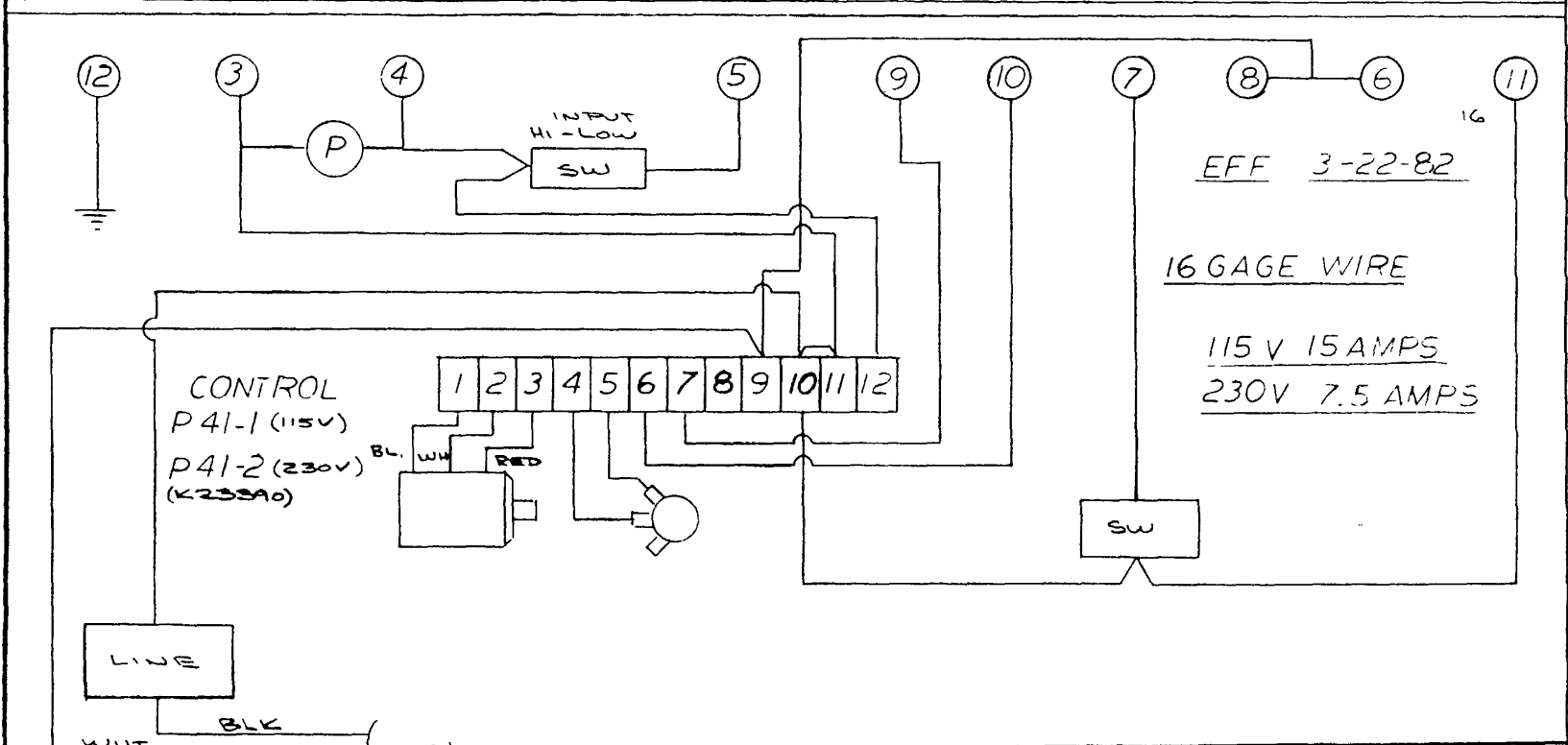
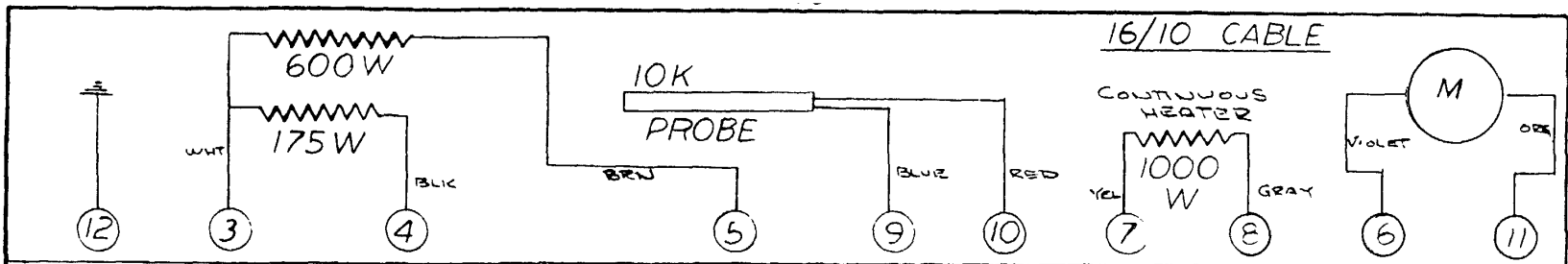

INSTRUMENT		K23300 & K23390		NO REQD		TITLE		KOEHLER INSTRUMENT CO INC	
MATL		FINISH		SCALE		SHEET 1 OF 1		1595 SYCAMORE AVENUE BOHEMIA N.Y.	
								PART NO WIRING DIAGRAM	

K23300 & K23390

SPARE PARTS LIST

<u>Part No.</u>	<u>Description</u>	<u>Quantity</u>
288-114-004	Stirrer Motor, 115V/230V	1 each
103DA	Coupling, Motor-Shaft	1 each
STD 102U-1	Motor Support	1 each
K233-0-10NS	Stirrer Shaft	1 each
K233-0-11	Stirrer Shaft Support	1 each
SS-RIF814ZZRA3	Ball Bearing	1 each
K233-0-3	Impeller	1 each
K233-0-4	Diffuser	1 each
K233-0-6A	Heater, 175W, 115V	1 each
K233-0-6A-2	Heater, 175W, 230V	1 each
K233-0-6B	Heater, 600W, 115V	1 each
K233-0-6B-2	Heater, 600W, 230V	1 each
K233-0-6C	Heater, 1000W, 115V	1 each
K233-0-6C-2	Heater, 1000W, 230V	1 each
K233-0-8	Cooling Coil	1 each
332-001-001	Pyrex Jar	2 each
050-001-001	Toggle Switch	2 each
050-001-002	Toggle Switch	1 each
045-115-001	Pilot Light Neon, 115V	1 each
045-230-001	Pilot Light Neon, 230V	1 each
010-010-002	10-Turn Potentiometer	1 each
010-001-001	1-Turn Potentiometer	1 each
010-103-001	Probe	1 each
010-010-001	10-Turn Dial	1 each
K233-0-5	Cast Iron Jar Support	1 each
K233-0-9	Leveling Screws	3 each
*K233-1	Tube Holder, Cannon Fenske	1 each
*K233-2	Tube Holder, Ubbelohde	1 each
010-115-003	Temperature Control Unit	1 each
010-230-002	Temperature Control Unit	1 each

*Catalog item - standard with bath.

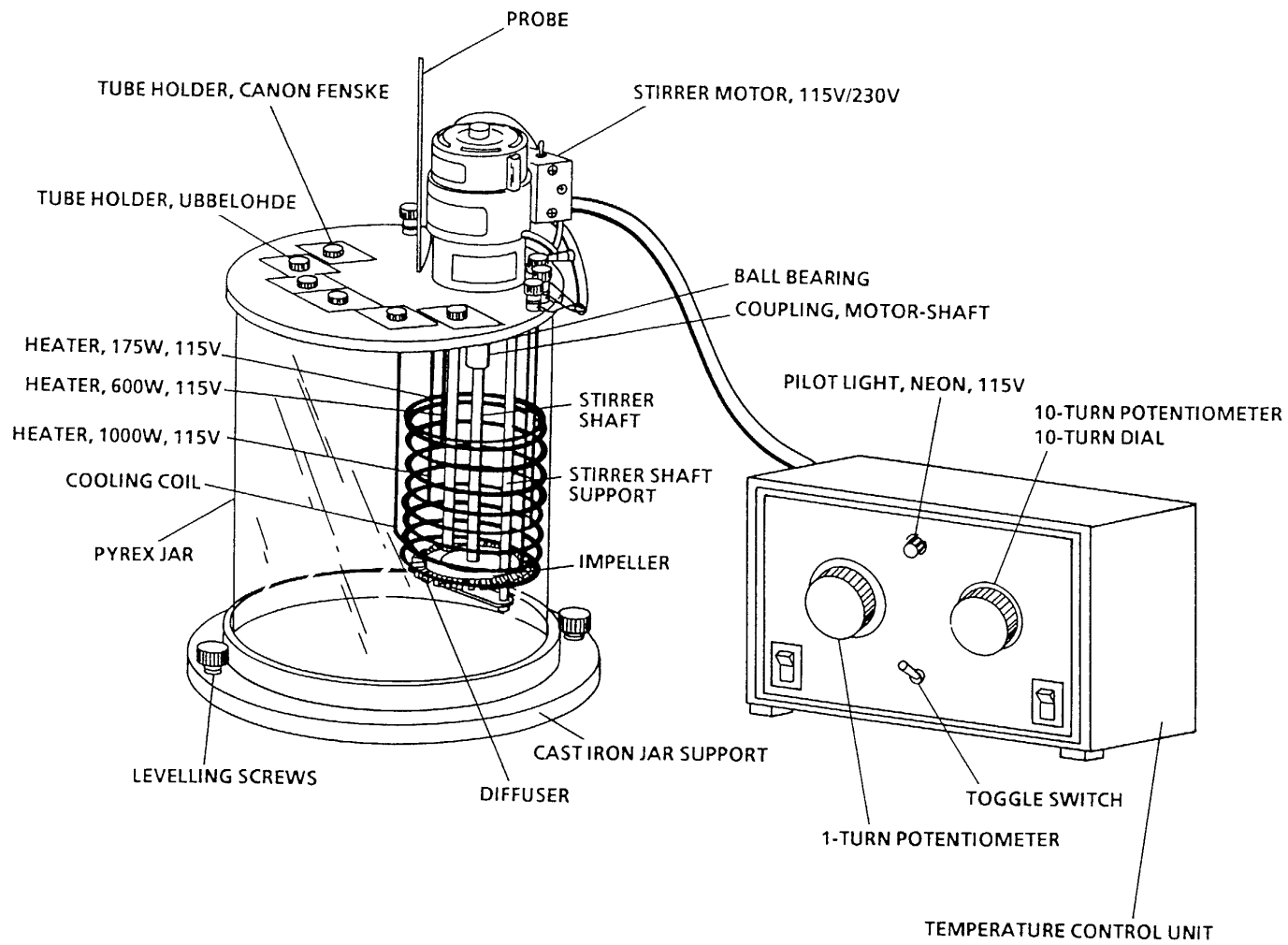



PRODUCT: K23380

Test Name: Kinematic Viscosity

Economy Kinematic Viscosity Bath

- Conforms to ASTM D445 and related specifications
- Solid state temperature control with thermistor sensor probe
- Temperature range from ambient to 2500F (121°C)

An economical constant temperature bath with high quality solid state control designed for use with glass capillary viscometers. Meets rigid ASTM specifications for bath temperature control precision, with accuracy of $\pm 0.02^{\circ}\text{F}$ ($+ 0.010\text{C}$) at temperatures of up to 2120F (1000C). Electronic solid state temperature controller has $+ 0.010\text{F}$ ($\pm 0.005^{\circ}\text{C}$) sensitivity at temperatures of up to 250°F (121°C). Controller incorporates a thermistor sensor probe in place of the mercury thermo regulator found in most kinematic viscosity baths, affording the operator both ease of use and accuracy. Make repeatable temperature settings directly from the control panel using ten-turn and one-turn reference control dials for coarse and fine adjustment. Copper immersion heaters of 1000W and 175W provide efficient heat transfer, and a 1/20 hp fan cooled stirrer thoroughly circulates the bath liquid to insure temperature uniformity.

Optional cooling coil allows bath to be operated at near ambient temperatures with the use of tap water or refrigerated coolant. Choice of 12" or 18" bath depth - 12" accommodates most types of viscometers.

Removable 1/2" (1.3 cm) Colorlith II™
top plate is machined to accept six round
viscometer holders, and supports heaters,
stirrer, thermistor probe, thermometer, and
optional cooling coil. Controls are mounted in a
separate housing connected to the bath by a
multi conductor plug-in cable. Control panel has
temperature controls, line switch and pilot light.

SPECIFICATIONS

Conforms to the specifications of:

ASTM D445, FTM 791-305, IP 71,
DIN 51550, ISO 3014

Capacity: Six (6) glass capillary
viscometers

Temperature Range: Ambient to 212°F
(100°C)

Controller Sensitivity: $\pm 0.01^\circ\text{F}$
($\pm 0.005^\circ\text{C}$)

Heaters: 1000W, 175W

Circulator: 1/15 hp, stainless steel
impeller

Bath Capacity, gal. (1):

Standard Model: 5.8 (21.9)
18-inch Model: 8.9 (33.5)

Bath Medium: Water

Dimensions:

Control Housing, 1 x w x h, in (cm)
9 x 8¼ x 6½ (23 x 21 x 17)

Bath, dia. x h, in. (cm)

Standard Model: 13¼ x 18 (34 x 46)
18-inch Model: 13¼ x 24¼ (34 x 62)

SHIPPING INFORMATION (Standard Model)

Net Weight: 35 lbs (15.9 kg) Shipping Weight:
91 lbs (41.3 kg) Dimensions: 28 x 24 x 43" (71 x
61 x 109 cm)

ORDERING INFORMATION

Supplied with Pyrex™ bath jar, thermistor probe, thermometer holder and six stainless steel port covers. Order viscometers, viscometer holders and bath thermometer separately.

Standard Model

Catalog No.	Description
------------------------	--------------------

K23380	Economy Kinematic Viscosity Bath 115V 50/60 Hz
--------	---

K23389	Economy Kinematic Viscosity Bath 220-240V 50/60 Hz
--------	---

18-inch Model

Catalog No.	Description
------------------------	--------------------

K23385	Economy Kinematic Viscosity Bath 115V 50/60 Hz
--------	---

K23386	Economy Kinematic Viscosity Bath 220-240V 50/60 Hz
--------	---

APPENDIX A
REFERENCES

A-1. **Scope.** This appendix contains all forms, pamphlets and technical manuals referenced In both the Air mobile and Semitrailer mounted Laboratories.

A-2 **Forms.**

Recommended Changes to Publications	DA Form 2028
	DA Form 2028-2
Quality Deficiency Report	SF 368
Equipment Inspection and Maintenance Work Sheet	DA Form 2404
Hand Receipts	DA Form 2062

A-3. **Field Manuals.**

Petroleum Testing Facilities	
Laboratories and Kits	FM 10-72
Inspecting and Testing Petroleum Products	FM 10-70
ASTM Test Method Supplement to	FM 10-92C1/C2

A-4 **Technical Manuals.**

Atlas-Copco Compressor	TM 10-4310-392-13&P
Alcor Jet Fuel Thermal Oxidation Tester Operating and Maintenance Manual	TM 10-6635-210-13&P
Bacharach Gas Alarm and Calibration Data	TM 10-6665-297-13&P
Brother Portable Typewriter	TM 10-7430-218-13&P
Chemtrix Field Ph Meter	TM 10-6630-237-13&P
Elkay Manufacturing 30 GPH Cooler	TM 10-4130-240-13&P
Emcee Micro-Separometer	TM 10-6640-222-13&P
Foxboro Pressure Recording Gauge	TM 10-6685-365-13&P
Gammon Aqua Glo Water Detector	TM 10-6640-221-13&P
Gammon Mini Monitor Fuel Sampling Kit	TM 10-6630-230-13&P
Jelrus Burn-Out Furnace	TM 10-6640-231-13&P
Koehler Cleveland Open Tester	TM 10-6630-236-13&P
Koehler Cloud and Pour Point Chamber	TM 10-6630-238-13&P
Koehler Copper Strip Corrosion Bomb Bath	TM 10-6640-220-13&P
Koehler Distillation Apparatus	TM 10-6630-233-13&P
Koehler Dropping Point Apparatus	TM 10-6635-211-13&P
Koehler Electric Pensky-Martins Tester	TM 10-6630-231-13&P
Koehler Foaming Characteristics Determination Apparatus	TM 10-6640-228-13&P
Koehler Kinematic Viscosity Bath	TM 10-6630-239-13&P
Koehler Tag Closed Cup Flash Tester	TM 10-6630-235-13&P
Lab-Line Explosion Proof Refrigerator	TM 10-6640-219-13&P
Lily Freezer	TM 10-6640-234-13&P
Millipore OM 39 Filter Holder	TM 10-6640-225-13&P
Millipore Vacuum Pump	TM 10-6640-217-13&P
Ohaus Harvard Trip Balance	TM 10-6670-278-13&P
Precision Gas-Oil Distillation Test Equipment	TM 10-6630-219-13&P
Precision General Purpose Water Bath	TM 10-6640-229-13&P

Precision High Temperature Bronze Block Gum Bath TM 10-6630-234-13&P
 Precision General Purpose Ovens TM 10-6640-218-13&P
 Precision Heater Instruction Manual and Parts List TM 10-6640-223-13&P
 Precision Oxidation Stability Bath TM 10-6640-232-13&P
 Precision Pensky-Martens Flash Testers TM 10-6630-231-13&P
 Precision Reid Vapor Pressure Bath TM 10-6640-226-13&P
 Precision Slo-Speed Stirrer TM 10-6640-224-13&P
 Precision Universal Centrfuge TM 10-6640-230-13&P
 Precision Universal Penetrometer TM 10-6640-228-13&P
 Sargent-Welch Vacuum Pump TM 10-4310-391-13&P
 Sartorius Analytical Balance TM 10-6670-277-13&P
 Scotsman Cuber TM 10-6640-227-13&P
 Soltec VOM-Multimeter TM 10-6625-3127-13&P
 Teel Self-Pnming Centrifugal Pump TM 10-6640-217-13&P
 Teel Submersible Pump TM 104320-320-13&P
 Texas Instrument TI-503011 Calculator TM 10-7420-210-13&P

A-5 Pamphlets.

The Army Maintenance Management System (TAMMS) DA Pam 738-750

A-6 Miscellaneous Publications.

The Army Integrated Publishing and Printing Program AR 25-30
 Laboratory, Airmobile, Aviation Fuel MIL-L-52733A(ME)
 Apparatus, Instruments, Chemicals, Furniture, and Supplies for Industrial,
 Clinical, College and Government Laboratories Fisher Scientific Laboratories Catalog
 Petroleum-Petrochemical Testing Equipment Precision Scientific Catalog

APPENDIX B

MAINTENANCE ALLOCATION CHART

Section I. INTRODUCTION

B-1 General.

a This section provides a general explanation of all maintenance and repair functions authorized at various maintenance categories.

b The Maintenance Allocation Chart (MAC) In Section II designates overall authority and responsibility for the performance of maintenance functions on the identified end Item or component. The application of the maintenance functions to the end Item or component will be consistent with the capacities and capabilities of the designated maintenance categories.

c Section III lists the tools and test equipment (both special tools and common tool sets) required for each maintenance function as referenced from Section II.

d Section IV contains supplemental instructions and explanatory notes for a particular maintenance function.

B-2 Maintenance Functions. Maintenance functions will be limited to and defined as follows:

a. Inspect. To determine the serviceability of an Item by comparing its physical, mechanical, and/or electrical characteristics with established standards through examination (e g, by sight, sound, or feel).

b. Test. To verify serviceability by measuring the mechanical, pneumatic, hydraulic, or electrical characteristics of an Item and comparing those characteristics with prescribed standards.

c. Service. Operations required periodically to keep an item in proper operating condition, I e., to clean (includes decontaminate, when required), to preserve, to drain, to paint, or to replenish fuel, lubricants, chemical fluids, or gases.

d. Adjust To maintain or regulate, within prescribed limits, by bringing into proper or exact position, or by setting the operating characteristics to specified parameters.

e. Align To adjust specified variable elements of an Item to bring about optimum or desired performance.

f. Calibrate. To determine and cause corrections to be made or to be adjusted on instruments or test, measuring, and diagnostic equipment's used In precision measurement. Consists of comparisons of two instruments, one of which is a certified standard of knob accuracy, to detect and adjust any discrepancy in the accuracy of the Instrument being compared.

g. Remove/Install. To remove and Install the same Item when required to perform service or other maintenance functions Install may be the act of emplacing, seating, or fixing. Into position a spare, repair part, or module (component or assembly) In a manner to allow the proper functioning of an equipment or system.

h. Replace. To remove an unserviceable Item and Install a serviceable counterpart in Its place. "Replace" is authorized by the MAC and is shown as the third position code of the SMR code.

i. Repair. The application of maintenance services, including fault location/troubleshooting² removal/installation, and disassembly/assembly procedures³ and maintenance actions,⁴ to identify troubles and restore serviceability to an item by correcting specific damage, fault, malfunction, or failure in a part, subassembly, module (component or assembly), end item, or system.

j. Overhaul That maintenance effort (service/action) prescribed to restore an item to a completely serviceable/operational condition as required by maintenance standards in appropriate technical publications (i e, DMWR). Overhaul is normally the highest degree of maintenance performed by the Army. Overhaul does not normally return an item to like-new conditioning.

k. Rebuild. Consists of those services/actions necessary for the restoration of unserviceable equipment to a like-new condition in accordance with original manufacturing standards. Rebuild is the highest degree of materiel maintenance applied to Army equipment. The rebuild operation includes the act of returning to zero those age measurements (hours/miles, etc.) considered in classifying Army equipment/components.

B-3. Explanation Of Columns In The Mac, Section II.

a. Column 1. Group Number. Column 1 lists functional group code numbers, the purpose of which is to identify maintenance significant components, assemblies, subassemblies, and modules with the next higher assembly. End item group number shall be "00".

b. Column 2. Component/Assembly. Column 2 contains the names of components, assemblies, subassemblies, and modules for which maintenance is authorized.

c. Column 3 Maintenance Function. Column 3 lists the functions to be performed on the Item listed in column 2. (For a detailed explanation of these functions, see paragraph B-2.)

d. Column 4. Maintenance Category. Column 4 specifies, by the listing of a work time figure in the appropriate subcolumn(s), the category of maintenance authorized to perform the function listed in column 3. This figure represents the active time required to perform that maintenance function at the indicated category of maintenance. If the number or complexity of the tasks within the listed maintenance function vary at different maintenance categories, appropriate work time figures will be shown for each category. The work time figure represents the average time required to restore an item (assembly, subassembly, component, module, end item, or system) to a serviceable condition under typical field operating conditions. This time includes preparation time (including any necessary disassembly/assembly time), troubleshooting/fault location time, and quality assurance/quality control time in addition to the time required to perform the specific tasks identified for the maintenance functions authorized in the maintenance allocation chart. The symbol designations for the various maintenance categories are as follows.

-
- 1 *Services - inspect, test, service, adjust, align, calibrate, and/or replace.*
 - 2 *Fault locate/troubleshoot- the process of investigating and detecting the cause of equipment malfunctioning; the act of isolating a fault within a system or unit under test (UUT).*
 - 3 *Disassemble/assemble - encompasses the step-by-step taking apart (or breakdown) of a spare/functional group coded item to the level of its least componency identified as maintenance significant (i e, assigned an SMR code) for the category of maintenance under consideration.*
 - 4 *Actions - welding, grinding, riveting, straightening, facing, remachining, and/or resurfacing.*

- C Operator/Crew
- O Unit Maintenance
- F Direct Support Maintenance
- H General Support Maintenance
- D Depot Maintenance

e. Column 5. Tools and Equipment. Column 5 specifies, by code, those common tool sets (not individual tools) and special tools, TMDE, and support equipment required to perform the designated function.

f. Column 6. Remarks. This column shall, when applicable, contain a letter code, in alphabetic order, which shall be keyed to the remarks contained in section IV.

B-4. Explanation Of Columns In Tool And Test Equipment Requirements, Section III.

a. Column 1. Reference Code. The tool and test equipment reference code correlates with a code used in the MAC, section II, column 5.

b. Column 2 Maintenance Category. The lowest category of maintenance authorized to use the tool or test equipment.

c. Column 3. Nomenclature. Name or Identification of the tool or test equipment.

d. Column 4 National Stock Number. The National stock number of the tool or test equipment.

e. Column 5. Tool Number. The manufacturer's part number.

B-5. Explanation Of Columns In Remarks, Section IV.

a. Column 1 Reference Code. The code recorded in column 6, Section II.

b. Column 2. Remarks. This column lists information pertinent to the maintenance function being performed as indicated in the MAC, section II.

Section II. MAINTENANCE ALLOCATION CHART

(1) GROUP NUMBER	(2) COMPONENT/ ASSEMBLY	(3) MAINTENANCE FUNCTION	(4) MAINTENANCE LEVEL					(5) TOOLS AND EQUIPMENT	(6) REMARKS
			UNIT		DS	GS	DEPOT		
			C	O	F	H	D		
01	BATH, KINEMATIC VISCOSITY	INSPECT REPLACE REPAIR	02	05 05				1 1, 2	

**Section III. TOOL AND TEST EQUIPMENT REQUIREMENTS
FOR
MAINTENANCE ALLOCATION CHART**

(1) TOOL/TEST EQUIP REF CODE	(2) MAINTENANCE CATEGORY	(3) NOMENCLATURE	(4) NSN	(5) TOOL NUMBER
1	O	TOOL KIT, GENERAL AUTOMOTIVE	5180-00-177-7033	(50980) SC 5180-90- CL-N26
2	O	MULTIMETER, 0-500V	6625-00-691-2453	

Section IV. REMARKS

NOT APPLICABLE

APPENDIX C

COMPONENTS OF END ITEM AND BASIC ISSUE ITEMS LISTS

Section I. INTRODUCTION

C-1. **Scope.**

This appendix lists components of end item and basic issue items for the Kinematic Viscosity Bath to help you Inventory items required for safe and efficient operation

C-2 **General.**

The Components of End Item and Basic Issue Items Lists are divided into the following sections

a Section II. Components of End Item This listing is for informational purposes only, and is not authority to requisition replacements. These items are part of the end Item, but are removed and separately packaged for transportation or shipment. As part of the end item, these Items must be with the end item whenever it is Issued or transferred between property accounts Illustrations are furnished to assist you in identifying the items.

b. Section III. Basic Issue Items These are the minimum essential items required to place the Kinematic Viscosity Bath in operation, to operate it, and to perform emergency repairs. Although shipped separately packaged, BII must be with the shelter during operation and whenever it is transferred between property accounts. The Illustrations will assist you with hard-to-identify items. This manual is your authority to request/requisition replacement BII, based on TOE/MTOE authorization of the end item.

C-3. **Explanation of Columns.**

The following provides an explanation of columns found In the tabular listings:

a Column (1) - Illustration Number (Ills Number) This column indicates the number of the illustration in which the Item is shown.

b. Column (2) - National Stock Number Indicates the National stock number assigned to the item and will be used for requisitioning purposes.

c. Column (3) - Description. Indicates the Federal Item name and, if required, a minimum description to identify and locate the item. The last line for each Item indicates the CAGEC (in parentheses) followed by the part number.

d Column (4) - Unit of Measure (U/M) Indicates the measure used in performing the actual operational/maintenance function. This measure is expressed by a two-character alphabetical abbreviation (e.g., ea., in, pr).

e Column (5) - Quantity required (QTY RQR) Indicates the quantity of the Item authorized to be used with/on the equipment.

Section II. COMPONENTS OF END ITEM

(1) Illus	(2) National Stock Number	(3) Description CAGEC And Part Number	(4) U/M	(5) Qty
		PYREX BATH JAR	EA	1
		THERMISTOR PROBE	EA	1
		THERMOMETER HOLDER	EA	1
		COVERS, PORT STAINLESS STEEL	EA	6

Section III. BASIC ISSUE ITEMS

NOT APPLICABLE

APPENDIX D

ADDITIONAL AUTHORIZATION LIST

Section I. INTRODUCTION

D-1. Scope.

This appendix lists additional Items you are authorized for the support of the Koehler Kinematic Viscosity Bath

D-2 General.

This list Identifies Items that do not have to accompany the Koehler Kinematic Viscosity Bath and that do not have to be turned In with it. These Items are authorized to you by CTA, MTOE, TDA, or JTA.

D-3. Explanation of Listing.

National stock numbers, descriptions and quantities are provided to help you identify and request the additional items you require to support this equipment. The items are listed In alphabetical sequence by item name under the type of document (i e , CTA, MTOE, TDA, or JTA) which authorizes the item(s) to you.

(1) National Stock Number	(2) Description CAGEC And Part Number	(3) U/M	(4) Qty Auth
	VISCOMETER	EA	
	VISCOMETER HOLDER	EA	
	THERMOMETER, BATH	EA	

D-1/(D-2 Blank)

APPENDIX E

EXPENDABLE/DURABLE SUPPLIES AND MATERIALS LIST

Section I. INTRODUCTION

E-1. **Scope.** This listing is for informational purposes only and is not authority to requisition the listed items. These items are authorized to you by CTA 50-970, Expendable/Durable Items (except medical, class V, repair parts, and heraldic items).

E-2 Explanation of Columns.

a. Column (1) - Item Number. This number is assigned to the entry in the listing and is referenced in the narrative instructions to identify the material (e.g., Use cleaning compound, item 5, appendix C).

b. Column (2) - Level. This column identifies the lowest level of maintenance that requires the listed item.

- C - Operator/Crew
- O - Unit Maintenance
- F - Direct Support Maintenance
- H - General Support Maintenance

c. Column (3) - National Stock Number This is the National stock number assigned to the item; use it to request or requisition the item.

d. Column (4) - Description. Indicates the Federal item name, and, if required, a description to identify the item. The last line for each item indicates the Commercial and Government Entity Code (CAGEC) in parentheses followed by the part number.

e. Column (5) - Unit of Measure (U/M) Indicates the measure used in performing the actual maintenance function. This measure is expressed by a two-character alphabetical abbreviation (e.g., EA, IN, PR). If the unit of measure differs from the unit of issue, requisition the lowest unit of issue that will satisfy your requirements.

Section II. EXPENDABLE/DURABLE SUPPLIES AND MATERIALS LIST

(1) Item Number	(2) Level	(3) National Stock Number	(4) Description	(5) U/M
	C		TECHNICAL OIL	OZ
	C		CORKS	EA

By Order of the Secretary of the Army:

CARL E. VUONO
General, United States Army
Chief of Staff

Official:

THOMAS F. SIKORA
Brigadier General, United States Army
The Adjutant General

DISTRIBUTION.

To be distributed In accordance with DA Form 12-21A, Operator, Unit and Direct Support Maintenance requirements for Laboratory, Petroleum, MTD

RECOMMENDED CHANGES TO EQUIPMENT TECHNICAL PUBLICATIONS

 <div style="border: 1px solid black; border-radius: 15px; padding: 5px; display: inline-block; margin-left: 20px;"> <p style="font-size: small; margin: 0;">THEN...JOT DOWN THE DOPE ABOUT IT ON THIS FORM. CAREFULLY TEAR IT OUT, FOLD IT AND DROP IT IN THE MAIL.</p> </div>				<h2 style="margin: 0;">SOMETHING WRONG WITH PUBLICATION</h2>							
FROM: (PRINT YOUR UNIT'S COMPLETE ADDRESS)											
DATE SENT											
PUBLICATION NUMBER		PUBLICATION DATE	PUBLICATION TITLE								
<div style="display: flex; justify-content: space-between;"> <div style="width: 30%; border-bottom: 1px solid black; padding-bottom: 5px;"> <p style="font-size: small; margin: 0;">BE EXACT PIN-POINT WHERE IT IS</p> <table border="1" style="width: 100%; border-collapse: collapse; font-size: x-small;"> <thead> <tr> <th style="width: 15%;">PAGE NO.</th> <th style="width: 15%;">PARA-GRAPH</th> <th style="width: 15%;">FIGURE NO.</th> <th style="width: 15%;">TABLE NO.</th> </tr> </thead> <tbody> <tr> <td style="height: 500px;"> </td> <td> </td> <td> </td> <td> </td> </tr> </tbody> </table> </div> <div style="width: 65%; padding-left: 10px;"> <p style="font-weight: bold; margin: 0;">IN THIS SPACE, TELL WHAT IS WRONG AND WHAT SHOULD BE DONE ABOUT IT.</p> <div style="border: 1px solid black; height: 400px; margin-top: 10px;"></div> </div> </div>				PAGE NO.	PARA-GRAPH	FIGURE NO.	TABLE NO.				
PAGE NO.	PARA-GRAPH	FIGURE NO.	TABLE NO.								
PRINTED NAME, GRADE OR TITLE AND TELEPHONE NUMBER			SIGN HERE								

The Metric System and Equivalents

Linear Measure

1 centimeter = 10 millimeters = .39 inch
 1 decimeter = 10 centimeters = 3.94 inches
 1 meter = 10 decimeters = 39.37 inches
 1 dekameter = 10 meters = 32.8 feet
 1 hectometer = 10 dekameters = 328.08 feet
 1 kilometer = 10 hectometers = 3,280.8 feet

Weights

1 centigram = 10 milligrams = .15 grain
 1 decigram = 10 centigrams = 1.54 grains
 feet
 1 gram = 10 decigram = .035 ounce
 1 decagram = 10 grams = .35 ounce
 acres
 1 hectogram = 10 decagrams = 3.52 ounces
 1 kilogram = 10 hectograms = 2.2 pounds
 1 quintal = 100 kilograms = 220.46 pounds
 1 metric ton = 10 quintals = 1.1 short tons

Liquid Measure

1 centiliter = 10 milliliters = .34 fl. ounce
 1 deciliter = 10 centiliters = 3.38 fl. ounces
 1 liter = 10 deciliters = 33.81 fl. ounces
 1 dekaliter = 10 liters = 2.64 gallons
 1 hectoliter = 10 dekaliters = 26.42 gallons
 1 kiloliter = 10 hectoliters = 264.18 gallons

Square Measure

1 sq. centimeter = 100 sq. millimeters = .155 sq. inch
 1 sq. decimeter = 100 sq. centimeters = 15.5 sq. inches
 1 sq. meter (centare) = 100 sq. decimeters = 10.76 sq.
 feet
 1 sq. dekameter (are) = 100 sq. meters = 1,076.4 sq. feet
 1 sq. hectometer (hectare) = 100 sq. dekameters = 2.47
 acres
 1 sq. kilometer = 100 sq. hectometers = .386 sq. mile

Cubic Measure

1 cu. centimeter = 1000 cu. millimeters = .06 cu. inch
 1 cu. decimeter = 1000 cu. centimeters = 61.02 cu. inches
 1 cu. meter = 1000 cu. decimeters = 35.31 cu. feet

Approximate Conversion Factors

<i>To change</i>	<i>To</i>	<i>Multiply by</i>	<i>To change</i>	<i>To</i>	<i>Multiply by</i>
inches	centimeters	2.540	ounce-inches	Newton-meters	.007062
feet	meters	.305	centimeters	inches	.394
yards	meters	.914	meters	feet	3.280
miles	kilometers	1.609	meters	yards	1.094
square inches	square centimeters	6.451	kilometers	miles	.621
square feet	square meters	.093	square centimeters	square inches	.155
square yards	square meters	.836	square meters	square feet	10.764
square miles	square kilometers	2.590	square meters	square yards	1.196
acres	square hectometers	.405	square kilometers	square miles	.386
cubic feet	cubic meters	.028	square hectometers	acres	2.471
cubic yards	cubic meters	.765	cubic meters	cubic feet	35.315
fluid ounces	milliliters	29.573	cubic meters	cubic yards	1.308
pints	liters	.473	milliliters	fluid ounces	.034
quarts	liters	.946	liters	pints	2.113
gallons	liters	3.785	liters	quarts	1.057
ounces	grams	28.349	liters	gallons	.264
pounds	kilograms	.454	grams	ounces	.035
short tons	metric tons	.907	kilograms	pounds	2.205
pound-feet	Newton-meters	1.356	metric tons	short tons	1.102
pound-inches	Newton-meters	.11296			

Temperature (Exact)

°F	Fahrenheit	5/9 (after	Celsius	°C
	temperature	subtracting 32)	temperature	

PIN: 046015-000